

SPRING 2022

# schoolbell

HIGHLAND CHRISTIAN SCHOOL

2.0



How to Be:

...Becoming who He wants us to BE



Evie is one of our celebrated Century Club readers. See article on page 9.

**HCS MISSION STATEMENT**

In order to honor God, we nurture and guide students to see the Father's creation to sense order in a world saved by Christ to serve God through the leading of the Holy Spirit

**CONTACT US**

3040 Ridge Road  
Highland, Indiana 46322  
219-838-0356  
www.highlandchristian.org

**PRINCIPAL** ..... Kyle Weener

**EXECUTIVE SECRETARY** ..... Jody Moes

**DIRECTOR OF RECRUITMENT AND DEVELOPMENT** ..... Jodi Lineburg

**SCHOOL BELL LAYOUT** ..... Christina Woo

**PRINTING** ..... Lithographic Communications

**2021-22 SCHOOL BOARD**

Jim Bandstra	Nancy Scheeringa
Curt DeGraff	Mike Schutt
Jerry Kuiper	Julie Sitter
Josiah Luttjeboer	John Stammers
Lon Natelborg	Deanne Van Rosendale

**2021-22 FOUNDATION BOARD**

Al Evers	Josh Scheeringa
Serita Jackson	Nancy Scheeringa
Caleb Jonkman	Dave Sherwood
Terry Krooswyk	Tim Spoelman
Jerry Kuiper	John Vander Pol
Mike Natelborg	Deanne Van Rosendale
Dave Neibert	Chris Yonkman
George Oostema	

# Christ At The Core

By Mr. Kyle Weener, Principal

## Proverbs 22:6: Train up a child in the way he should go; even when he is old he will not depart from it.

Is April too late for a winter analogy? If you said yes, you might be in denial about the Easter flurries from 2020. Thinking back to winters (and yes, springs too) spent as a kid in West Michigan, most weekends were filled with snow fun. Whether riding the snowmobiles, watching Dad plow the driveway with his bright red tractor, or sledding down the big hill out back, my three younger siblings and I always found ways to have fun in the snow - building forts, having snowball fights, and "attempting" to get along.

As kids, we always waited for the perfect weather to make the first snowman of the year. If the conditions were not perfect, the likelihood of success would be limited. Starting with the right core (a perfect snowball), we could easily pick up traction to turn our snowball into the base of our snowman. At any point in this process, if the original snowball became compromised, it would be impossible to continue.

Over the past 113 years, Highland Christian has been steadily built on the right core - God's word. Throughout the test of time, our community has banded together to vivaciously support our mission and vision - to not only academically equip, but to biblically ground and spiritually nurture children to impact the world for Christ. **Our core beliefs and values are the reason why we desire our children to be a part of Highland Christian.**

After improving academic outcomes for all students, embedding faith integration into everything we do, and providing access to financial support through internal and governmental resources, it is no surprise to see the growth we have encountered (adding nearly 100 new students in the past three years alone). We praise God for His blessings and faithfulness!

While growth is exciting, it is imperative that our core remains firmly intact. As the Board and administrative team implements policy, our history of immovable Reformed values and Christ-centered education remains the essential base of all we build. **Highland Christian's goal is not to be the biggest school possible, but to provide every student and family who desires it, an excellent education built on a distinctively Reformed perspective.** As I meet new mission and vision-matched families seeking Christian education, there is no place that I would rather be than here at Highland Christian - serving these cherished children.

Thank you for the important part YOU play in seeing the next generation grow in God's love.

By Mr. Rick Vander Woude

We live in a culture in decline - spiritual and otherwise. One of the consequences of this has been the denigration of males as passive, toxic, and immature. Dr. Anthony Bradley, Professor of Religious Studies, The King's College, New York City, has been observing, studying, and writing about this phenomenon for over 20 years. Besides describing the long-term devastating effects of this trend and what hasn't worked, he has prescribed some helpful practices. These included men, among other things, coming alongside boys, teaching them, and encouraging them.



# BUILDING UP BOYS

About a year and a half ago, Mr. Krooswyk and I began discussing the negative effects that our broader culture, as described above, has on men and boys and how we might "flip the script" for junior high boys at Highland Christian School. Determined to be part of the solution, we formed a coalition and planned an

activity which would bring men and boys together for a time of informative fellowship. The initial activity involved men speaking about their situations and occupations with the goal of bonding and encouragement amongst the boys in a Christian setting. Four men from our school community, **Mr. Jeremias Alicea**, parent and teen educator; **Mr. Lloyd Colar**, parent and youth leader; **Mr. Juan Cruz**, youth pastor; and **Mr. David Sherwood**, parent and HCS coach, enthusiastically supported the idea as did the HCS School Board of Directors.



Mr. Krooswyk and I are deeply appreciative of the time these four men are investing in our young boys' lives. Following an initial organizational meeting, we agreed that it would be reasonable to meet once a month, with the first meeting on Jan 28, 2022. As any good gathering does, these monthly meetings involve a speaker, some time for fun, and good food. One of the highlights of our February meeting was the catering done by a dad, Mr. Herman Miller, who runs his own business - **Herm's Grill**. Monthly meetings will be scheduled ideally for the last Friday of each month from 3:30 to 5:30.



Mr. Alicea, Mr. Colar, and Mr. Cruz have participated as speakers and leaders. **Mr. Dan Kuiper**, an HCS alum, will speak for the April meeting. Attendance has been outstanding and affirms the need for opportunities like this. As we forge ahead with plans for the next school year, we invite you to influence and build up these young men with us!

If you are interested in using your skills, input, and experiences to encourage our boys as they grow into Christian men, please contact Mr. Rick Vander Woude (edtechcoach@highlandchristian.org) or Mr. Neil Krooswyk (nkrooswyk@highlandchristian.org).



## Sonshine Enrichment Center Growing Stronger, Learning More!

By Mrs. Karen vanBelle

One of the goals of preschool is Kindergarten Readiness. Each day is filled with activities that are fun, but also serve to bring us closer to that goal. As we draw closer to the end of the school year, it's great to look back and see some of the highlights of the last few months and how they helped us get ready for the future!

We pray several times each day at preschool. It's important to talk to God, and we make time to do that. Our favorite prayer this month is the "Superman Prayer"! We pray this at snack time and at lunch time. We talk about how God loves to hear from us and how we can talk to Him anytime. It's great to know that He cares for us!

We love P.E.! We do different activities each week. One of our favorites this winter was having indoor snowball fights! Following the rules of dodgeball, we used large pom poms in the gym for our "snow" battles. We're developing our large motor skills, following rules, and getting physical activity.

Choice Time is a daily favorite. Students have a variety of stations to choose from, and they move through them as they wish. This time is used to foster independence, social skills, teamwork, and conflict resolution. However, the available choices also create opportunities to be creative, practice fine motor skills, solve problems, and celebrate our accomplishments together.

Field trips are a special treat! In January, we went to Funflatables. The students had a great time working their large motor muscles, and the parents and teachers enjoyed time to connect with each other. Getting out into our surrounding community helps students learn observation skills, how to interact with adults, and practice social skills in different settings.

Rhythm sticks are another special treat. We see our students connect with music in many great ways! Listening skills and following directions are very important during these times. We're also learning



to hear and make a steady beat as well as crossing the mid-line of our bodies. Doing this encourages coordination and brain connections. It's a fun way to help our brains get stronger!

These are just a few of the ways we're working to get ready for all the great things that are in our futures. We're growing stronger and learning more about God and His world every day!

## Opposite Day

By Mrs. Sara Jabaay

On what appeared to be a "Freaky Friday", the fourth grade students swapped places with their teachers! The students worked in groups to create lessons the week before that matched the content they'd be learning that day. Mrs. Kruihof and Mrs. Jabaay stepped back as the students took charge of their teaching and learning. Students made lessons with attention-grabbers, a focus on standards, and assessment pieces. One of their favorite parts was getting to experience the Bible come alive with a treat of homemade manna. (It was better than it sounds.) Students learned that teaching is a hard job, but also a calling. It was great to see students use their gifts from God in this way!



## Book Fair & Book Week

By Mrs. Judy H. Zandstra

This year's Book Fair was widely successful! Did you know that half of the profits from the Book Fair come back to Highland Christian School through Scholastic Dollars? So, when you restock your bookshelves at home, we're able to restock the library shelves too! We are so grateful for the support shown to the library through the fair. We are especially grateful to all the volunteers who help out each year to make the fair possible

Excitement about new books (and accessories) is a huge benefit for rising readers, and avid readers can't wait for us to get the latest book in their favorite series. To add to the excitement, the school also celebrates reading through Book Week. As you can see from the pictures, the highlights of Book Week were the days where students and teachers dressed up like each other and dressed up like their favorite book character.



# Supporting Student Learning

By Mrs. Melissa Brouwer

For many years Northwest Indiana Special Education Cooperative (NISEC) has been responsible for providing occupational therapy, physical therapy and speech/language therapy for students at Highland Christian School. While we have benefited greatly from this partnership, over time, service provision has changed.

NISEC serves a total of 8 school districts, which includes many private schools. Because these providers are shared, they provide services when their schedule allows, not necessarily when it works best for the student. At times students are pulled from their classroom during core instruction, such as math or reading, to receive occupational therapy or speech/language services. Currently, students with speech/language needs in our building receive services through a virtual platform called Tiny Eye. Having students participate in virtual speech/language services is not ideal.

In order to best serve the students with these needs, we have begun the process of moving away from NISEC services. While NISEC will still be responsible for evaluating students, when a need for service is determined, we will work with the family to create a plan to deliver the necessary services.

To this end, **Highland Christian School has the opportunity to access funding earmarked for student support services and will be hiring our own Speech/Language Pathologist, Occupational Therapist and Physical Therapist.** Having our own staff to work with students at ideal times and provide the best quality services is our goal.

Giving each child what they need to succeed is one way we live into our calling of ensuring that students are academically equipped. While this is a great step forward in meeting student needs, services will still be limited to the mild to moderate range of need.

We recognize the balance of responsibility and need for honesty with families about what we can offer and what needs we are able to meet. By providing these services with consistency and integrity, we hope to further support enrolled HCS students who have speech, processing, and motor skills, that without support, would negatively impact their education.



# American Legion Flag Education

By Mrs. Sara Jabaay

For several years, HCS fourth graders have been participating in the American Legion's Flag Education Test Program. Each student participating in the Flag Education Test Program takes the same test. The answers on the test are scored against a standardized answer sheet. The "Our Country's Flag" comic book is used as a study guide for the closed book test. The test consists of 20 questions, which vary from multiple choice to true and false. They also write an essay about what the flag means to them. Two students at each participating school are chosen as school winners.

American Legion members commented that HCS students usually do very well in the competition, but this year one of our students, Hallie Sitter, was chosen as the top female winner for all students in District 1 (Lake County) of the Indiana American Legion! Hallie scored perfectly on the multiple-choice portion of the test and her essay was selected from about 1,200 other students in our region as the top essay submission.



Hallie was honored for her achievement by the District 1 Legion members at their March meeting. She read her essay aloud and was presented with a special certificate to commemorate her accomplishment. In addition, she was presented with an American Flag that was flown over the Capitol Building in Washington DC. Well done, Hallie!

# ISSMA

By Mrs. Judy H. Zandstra

Highland Christian School students have the opportunity to participate in two Indiana State School Music Association (ISSMA) competitions each year. One event focuses on piano and vocal performance, while the other event features instrumentals. Students who participate in this competition are evaluated on preparation and performance of their musical piece.

ISSMA judges provide feedback for students to help hone their performance and musical skills. Students are awarded gold, silver, or bronze medals, based on their performance. This is a great opportunity for students to receive an objective educational critique of their musical level and presentation skills.

This year, 9 students participated and received medals.

The following students medaled in the piano competition: Addie B. (Gold), Adelia E. (Silver), Jacob E. (Gold), Noah F. (Silver), Dane S. (Gold) and Grant S. (Gold).

These students received Gold in Instrumental Performance: Addie B., Rashawn J., Nathanael K., and Myles M.



# Engineering Solutions & Freeze Pops

By Mrs. Joy Verkaik

The 2nd graders have been hard at work on the PLTW project these past few weeks. They were given a challenge to use the engineering design process to design and create a prototype that would keep a freeze pop frozen for one hour. They applied what they learned about matter, conductors, and insulators to their project. The students used tin foil, styrofoam, boxes, and cardboard to create their prototypes. The students loved applying their science knowledge, building with a group, and making a mess.



# Why Highland Christian School?

Scott and Mary Falvey, Parents

Determining what is best for our children academically isn't a decision we take lightly. Every spring we found ourselves asking the same question, "What are we going to do for school next year?" As my own academic path was a predictable one – attending the neighborhood's public school and remaining in the same system for grades 1-12, I used to think that whatever path we chose for our children's education would be consistent throughout their school-aged years. I quickly learned that this is not the case, and the answer to our question would not be a one-size-fits-all answer. This is why our three children have had a variety of experiences over the past 10 years, including attending Montessori, a private preschool, the public school where we live, and homeschooling.

After five years of homeschooling, spring 2021 came around and we felt God prompting us to reevaluate our situation once again. We began our search by communicating with the local public school and visiting a nearby private school for our soon to be freshman, 6th grader and kindergartner. Within a few weeks, God made it clear that we hadn't found the right fit yet, so we scheduled a tour at Highland Christian School.

*Now, a year later, instead of asking ourselves that predictable question, "What are we going to do for school next year?", we find ourselves humbly overwhelmed with contentment and gratitude. God has continued to affirm HCS as a unique place where our children have been able to grow not only academically, but also spiritually, physically and emotionally.*

We were instantly impressed with the school's attempt to meet the needs of each individual (WIN time, Power Hour, and leveled reading groups to name a few) and the variety of programs available to engage and challenge students (Quest, Project Lead the Way, etc.). As pleased as we were with the potential academic opportunities our boys would have at HCS, we were struck even more by the welcoming and encouraging Christian atmosphere of the school and the opportunity for their spiritual growth. This was the clarity we needed to move forward and felt confident enrolling our boys for the 2021-2022 school year.

Fall approached, and we quickly settled into our new routines at HCS. It didn't take long to reaffirm the choice we had made for our family. Clearly, this was a place where God's word is not only woven into all areas of the curriculum, but this year's school theme of "Just Live It!" is modeled and lived out by both teachers and students daily. Walking down the hallway, it is not uncommon to witness a group of middle school boys learning cooperatively– fully engaged in their project, hear a first-grade teacher speak affectionately to her students, or see the children skipping in through the front door, voluntarily held open by a peer offering up a cheerful greeting.

Now, a year later, instead of asking ourselves that predictable question, "What are we going to do for school next year?", we find ourselves humbly overwhelmed with contentment and gratitude. God has continued to affirm HCS as a unique place where our children have been able to grow not only academically, but also spiritually, physically and emotionally. And beyond the obvious gestures one might observe of the students and faculty "Just Living It" that initially impressed, we have been privileged to learn that God's love penetrates the HCS community even deeper than we could have realized– revealing Himself through the dedicated mom who faithfully prays for all of our children and teachers despite no longer having students herself at HCS, the sound of a chorus of recorders joyfully playing "Amazing Grace" together, the paragraphs of scripture memorized and simultaneously shared by fifty beautiful five and six-year-old voices, the artwork on the wall reflecting each child's identity in Christ, the kindergarten teacher who has spent her entire career pouring into students at HCS, and the reassuring words to a worship song carefully chosen for this week's chapel intended for the students, but are exactly what you need to hear.

For all of these things, and so many more, we feel so blessed to have become a part of this special community. Thank you, from the bottom of our hearts, for all of the hard work and energy that is poured into our children each and every day and for giving us the confidence that our children are exactly where they need to be.

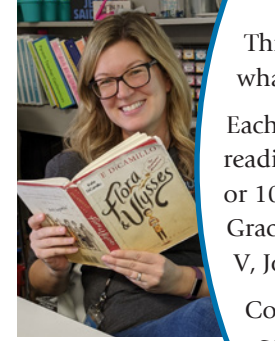

## Reader's Century Club

By Mrs. Judy H. Zandstra

This Reader's Century Club is a club anyone can join, as long as you keep track of what you are reading!

Each of our members has read either 100 picture books or 5,000 pages! That is a lot of reading, but not an impossible amount. Some of these readers have read over 200 books or 10,000 pages this year!! Members of our Reader's Century Club include: Maria B, Gracyn D, Julia F, Emma J, Grace J, Carina M, Matthew N, Noah R, Shelby S, AJ V, Evie V, John W, Maddie W, Mrs. Huizenga, Mrs. Jabaay, Mrs. Reynhout, and Mrs. Zandstra.

Congratulations to our Century Club members on your accomplishment! You are getting smarter and more prepared with every book you read!

To read daily is a commendable goal. Did you know in addition to improving your general knowledge and vocabulary, it also helps you improve your writing and memory skills? It also helps you develop a greater sense of empathy while improving your own mental health.

Are you up for the challenge? We invite you to join us in this quest and will welcome new members until the end of the year!

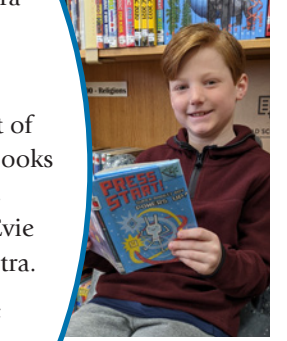
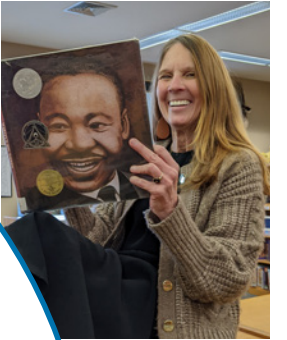
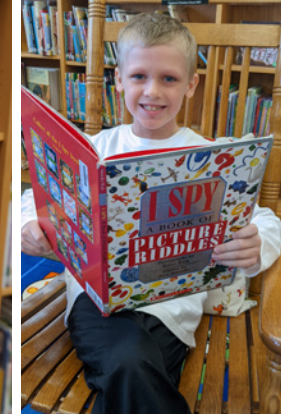

# Special Interest Clubs at HCS

By Mrs. Judy H. Zandstra

Did you know that extracurriculars benefit students in a variety of ways? Giving kids an opportunity to explore their interests can actually contribute to better concentration, time management, and focus. Highland Christian School has always provided extracurricular activities for students, namely sports and musicals, but over the past few years, many new clubs have sprung up at HCS!



HCS's staff members are excited about all these clubs because they provide students opportunities to get involved, strengthening relationships with their peers and teachers. They encourage the development of new skills and promote a personal sense of accomplishment for students. Each of these clubs explore an expressed interest of students. Some clubs are initiated by teachers and some are initiated by students. Some clubs are academic and some are just for fun. As these clubs are interest driven, future opportunities are wide and varied!

After school clubs include Math Pentathlon for grades 2 through 5, Chess Club, initiated and led by sixth grade student, Jonah Van Ek for grades 2 and 3, Read and Destroy Book Club for 3rd and 4th grade students, and Girls on the Run for 3rd through 5th grade girls. The Rubik's Cube Clubs are during 4th grade's lunch recess and Jr High Power Hour. During Jr High Power Hour there is also a Book Club that is reading "a Wolf Called Wander" and a Fall Chess Club.



# 7th Grade Boys Volleyball

By Coach Lisa Blocker

Working very hard with fundamentals and learning the game of volleyball, the 7th grade team improved so much by the end of the season! Having only two wins throughout the regular season, they came back with vengeance during the final tournament, to take 3rd place in three games, defeating Heritage Christian School. **Great finish!**

7TH GRADE TEAM Diego Jimenez, Zinabu Bosman, Jordan Smith, Ari Smit, Myles Miller, Ethan De Boer, James Dillon, and Micah Wieringa



# 8th Grade Boys Volleyball

By Coach Lisa Blocker

With a 3-3 record for the regular season, the 8th grade team rallied together and learned how to use each other's gifts to execute their best! They went head-to-head with Crown Point Christian in the final tournament, who they had lost to twice during the regular season. They ended up pulling out the win in two games, and finished 1st place out of the 8 teams in the tournament. **Great job boys!**

8TH GRADE TEAM Jaydon Colar, Caleb Kieft, Spencer Bandstra, Carlos Rivera, Micah McGuire, Gavin Jones, Matthew Neibert, Alan Kuzmar, Dane Scheeringa, and Christian Castro



## Wish List

- Office**
- Amazon Basics
- 150-Sheet Paper Shredder . . . . \$250.00
- Quest**
- K'nex Educational STEM Set. . . \$165.00
- Byrdseed.TV.
- One Year Subscription . . . . . \$119.00
- Teachers Pay
- Teachers Gift Cards . . . . . any amount



## 6th Girls' Basketball

By Coach Neil Krooswyk

The 6th grade girls' basketball team had a great season. These girls worked hard and their improvement was evident in the end of the year tournament. A highlight was finishing second in this tournament and ending the season on a positive note. Many of the girls were on a team for the first time and they did a great job. The team included Kinley Vander Pol, Wren Weinberg, Abrielle Brown, Adeline Buikema, Mikayla Colar, Hayden Cristler, Jordyn McGuire, Jayden Parks, Liv Scheeringa, Jasmyn Spraggins, and Xochitl Garcia.

## 6th Boys' Basketball

By Coach Dave Sherwood

The 6th grade basketball team had a very successful season. These boys won many games and showed their improvement by winning the 6th grade tournament. This was a big team that showed great teamwork and attitude the whole season. The team included Cameron Katz, Nathan Sherwood, Kade Blocker, Nathanael Koutz, Rashawn Johnson, Jaiden Budna, Zachary Clark, Grant Sitter, Jonah Van Ek, Anthony Flowers, Elliot Molenaar, and Jozef Nelson. I am proud of what the team accomplished and look forward to seeing them improve in the next two years.



## 7th Girls' Basketball

By Coach Dan Aardsma

The 7th grade girls' basketball team finished the season 1-5, ending with a win against DeMotte Christian in the tournament. We had a great group of nine girls on the team. We had to recruit some helpers to fill the final spot for a full practice (sometimes even the coach had to play). The girls did not get in as many games as in previous years, due to a lack of teams in the league and weather postponements. We saw drastic improvement in the girls' skills and teamwork as the season progressed, and they became better competitors toward the end.

One of the highlights of the season was when Claire Aardsma represented the Huskies well by winning the Individual Free Throw Contest, making 5 out of 6 in the final round. Overall, we learned to understand the game better, the importance of playing hard as a team, and had a lot of fun doing it. Team members: Claire Aardsma, Natalie Bantsolas, Piper Constantino, Olivia Figueroa, Alanna Lee, Addison Mills, Edyn Ooms, Mallory Otto, and Kerren Williams.



## 7th Boys' Basketball

By Coach Dave Sherwood

The 7th grade basketball season was another good year that ended with a great 2nd place finish in the tournament. This team worked together well and had a great showing in the tournament. I'm excited to see their hard work displayed in their 8th grade season next year. The team included Zinabu Bosman, Jonathan Escamilla, Ari Smit, Myles Miller, Diego Jimenez, Chris Howell, Nathan Sherwood, Kade Blocker, and Cameron Katz.



## 8th Girls' Basketball

By Coach Neil Krooswyk

The 8th grade girls had an exciting season, ending with a great showing in the tournament. The team faced injuries and challenges, but worked hard all the way to the end of the season. The highlight came in the tournament when the girls beat DeMotte in a thrilling game after losing in overtime earlier in the season. These girls did a great job representing HCS. The team included Alise Evenhouse, Atoriah Flowers, Natalia Avila, Kacie Carter, Jalea Glasper, Riley Jellema, Lailoni Staten, Avery Van Laten, and Jadyn Spraggins.

## 8th Boys' Basketball

By Coach Neil Krooswyk

The 8th grade season was one for the books. This team went through highs of winning big games and the lows of injuries and tough games. They were able to put it all together for the tournament in a great end to their 3 years. The boys beat Crown Point in overtime to advance to the championship game. The team then won the championship against an impressive Calvin team that we lost to by 20+ in the regular season. The boys worked extremely hard and displayed awesome teamwork and grit. The boys ended their season as champions. I am so proud of this group and thankful that I was able to coach a group of great young Christian men. The team included Caleb Kieft, Spencer Bandstra, Gavin Jones, Jaydon Colar, Dane Scheeringa, Micah McGuire, Nick Neibert, Jace Ooms, Luke Huizenga, Alan Kuzmar, Logan Van Prooyen, and manager Aiden Cisneros.





## WE'RE HIRING!

Highland Christian School is currently seeking to hire a new Transportation Coordinator for the 2022-2023 School year.

For more information, please contact the Office at (219) 838-0356.



## Camp Invention®

By Mrs. Judy H. Zandstra

Register NOW! Camp Invention will be hosted at Highland Christian School **June 13th-17th.**

This is our seventh year with Camp Invention and each year it gets better! This week is filled with innovation and fun, building on the STEM opportunities your kids have had during the school year. Camp is a great time for your children to explore all those ideas that they have! Through Camp Invention, we aspire to cultivate curiosity and develop children's critical thinking skills. Who knows, maybe your child will "innovate the next best thing".

**Go to [invent.org](http://invent.org) to find out more about this fun and exciting week, or contact Judy H. Zandstra with any questions.**

# alumni INfocus

## Christina Eenigenburg Class of 2007

### How did your story unfold?

After HCS, I continued to Illiana Christian High School. My initial plan after graduation was to go straight to a 4-year college, but instead, I decided to go to cosmetology school first. I aspired to use that trade to make additional money during college and then to have that skill for a flexible job later in life. I was determined to return to college but if anyone else can relate, God always gives me the last laugh by thinking I am going to plan my own life.

Back track to my Senior year of high school when I signed with my modeling agency in Chicago. NEVER in my life did I think of or strive to model professionally. After a few people planted seeds, a "why not" mentality emerged, and I went to an open call with no expectations. I was shocked when the agents wanted to sign me. Within a year and a half, I had a full-time career in the modeling industry and had graduated with my cosmetology license working as a stylist part time.

Eleven years later I am still fortunate enough to be modeling professionally and couldn't be more thankful for the friendships and experiences along the way. Within the last 3 years I gained my license as a realtor. God again played a huge role when I enrolled in real estate school. I earned my license shortly before the pandemic. Not long into the pandemic the housing industry boomed, modeling became extremely slow at the time and God provided a job for me. The real estate team I joined is Christ-centered with a life/business motto of Christ first, family second, and business follows. Their work ethic has been inspiring to be a part of.



On a more personal side, I got married around my mid 20s and because of my husband and the hard work we have put into our relationship, there are so many things that I just love about being married.

### How has the foundation of Christian Education served you in your adult life?

I was very fortunate to have my parents put me through Christian education all through grade school and high school. I feel it played a huge role in my adult life. It was a positive environment of structure, learning and teachers who cared deeply for their students. I have many good memories that I can still recall from every grade at HCS. I even have friends I made in kindergarten that I am still friends with today.

### Did any particular teacher impact you in your youth? If so, who?

I had several teachers at Highland that I would consider my favorites, for various reasons. One that stands out in my mind would be my art teacher, Mrs. Otte. I have always had a passion for art and creativity, and she recognized that early on. She encouraged me and pushed me to be better. She assisted in getting me into the extracurricular art

class at Southridge Grade School and found opportunities to put my love of art to use. To this day, I look for ways to incorporate art + creativity in my life, whether that be volunteering at Highland Christian School's thrift store, ETC, with putting up the displays, modeling, being a hairstylist, selling artwork on the side and the list goes on.

### With the understanding you have today, what advice would you give the younger you?

God's plans for you will always be better than you can conjure up yourself, even if you can't see it in the moment. The anxiety you put yourself through trying to figure it out isn't worth it.

### What experiences do you identify as contributing to/anchoring in your faith, stewardship, compassion, and service mindset?

I would say my service mindset was taught early. Growing up, I saw how much my parents were involved, donating their time within HCS, our Church and helping people around them. I saw first-hand how our Christian community naturally shows up with support when needed. This I something I grew to really appreciate as I got older. And that is another reason why I volunteer at the ETC thrift store. I want to give back and contribute so more students have the possibility to get the Christian education HCS provides.

It's hard to pinpoint exact experiences that anchored my faith. Some of the deepest roots in my faith developed as I learned to navigate in a career that tested my faith and my values many times. I had to make growing my relationship with Christ a priority and remember what I was taught growing up. Having genuine friends that hold you accountable are irreplaceable and a gift. I feel truly blessed to have my closest friends in my life.

**SAVE THE DATE  
MAY 5TH & 6TH**

You are sure to be entertained by this year's musical extravaganza, HIGH SCHOOL MUSICAL JR - where all the drama is fun! On May 5th and 6th you can experience an evening with the "WildCats" as they try to put on a High School Musical. Join us for dinner in the Wildcats cafeteria and watch the drama unfold as the cast explores the experiences and emotions of High School. Who will be picked for the lead roles? Who will be able to rise above the stereotype role their peers have given them? Who needs help to truly be a good friend? The cast is working hard and we know you'll enjoy their performance! So, save the date today and we'll look forward to seeing you then!



# Summer 2022 Building Projects

We're in the home stretch! As we near the end of the 2021-2022 school year, we're gearing up for summer projects. This summer a portion of the library, office, and computer lab will be remodeled to create additional office spaces and a small multipurpose room. We will also be razing the current storage garage and erecting a new larger, storage facility near the soccer field. This will address a variety of emergent needs with storage as well as provide additional parking spaces as we enter the new year. You can catch a sneak peek of all that's to come in the drawings shown here. We are grateful to the Building and Grounds committee for their hard work and time invested in maintaining and upgrading our facilities.

Multi-Purpose Room

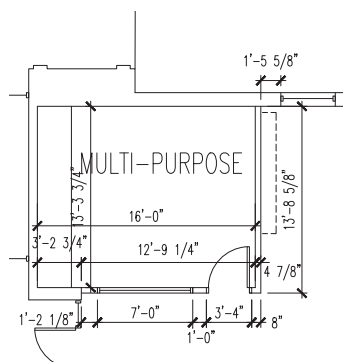

Additional Office Space

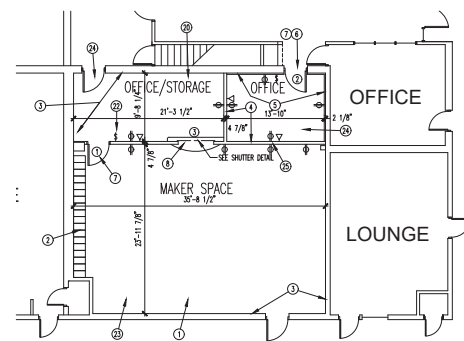

Storage Facility

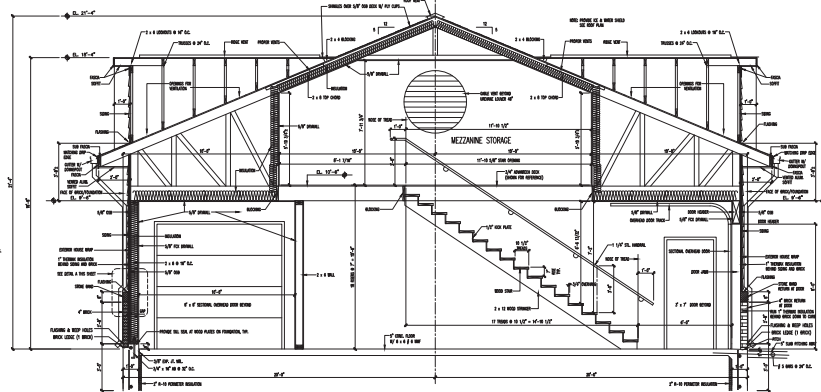

## 2023 Expansion Proposal



We've recently announced our intent to expand! You can follow along with the plan and progress online at [www.highlandchristian.org/2023Expansion](http://www.highlandchristian.org/2023Expansion). We're excited about the opportunity that God has entrusted to us in this and look forward to the way this story will unfold.

Built to serve serve Christian families, whose commitment to Christ is demonstrable through participation in worship and formal church membership, this proposed expansion plan allows us to maximize our impact, meet the needs of current & emerging enrollment, optimize teacher to student ratios, and regain learning spaces that have temporarily been reassigned.

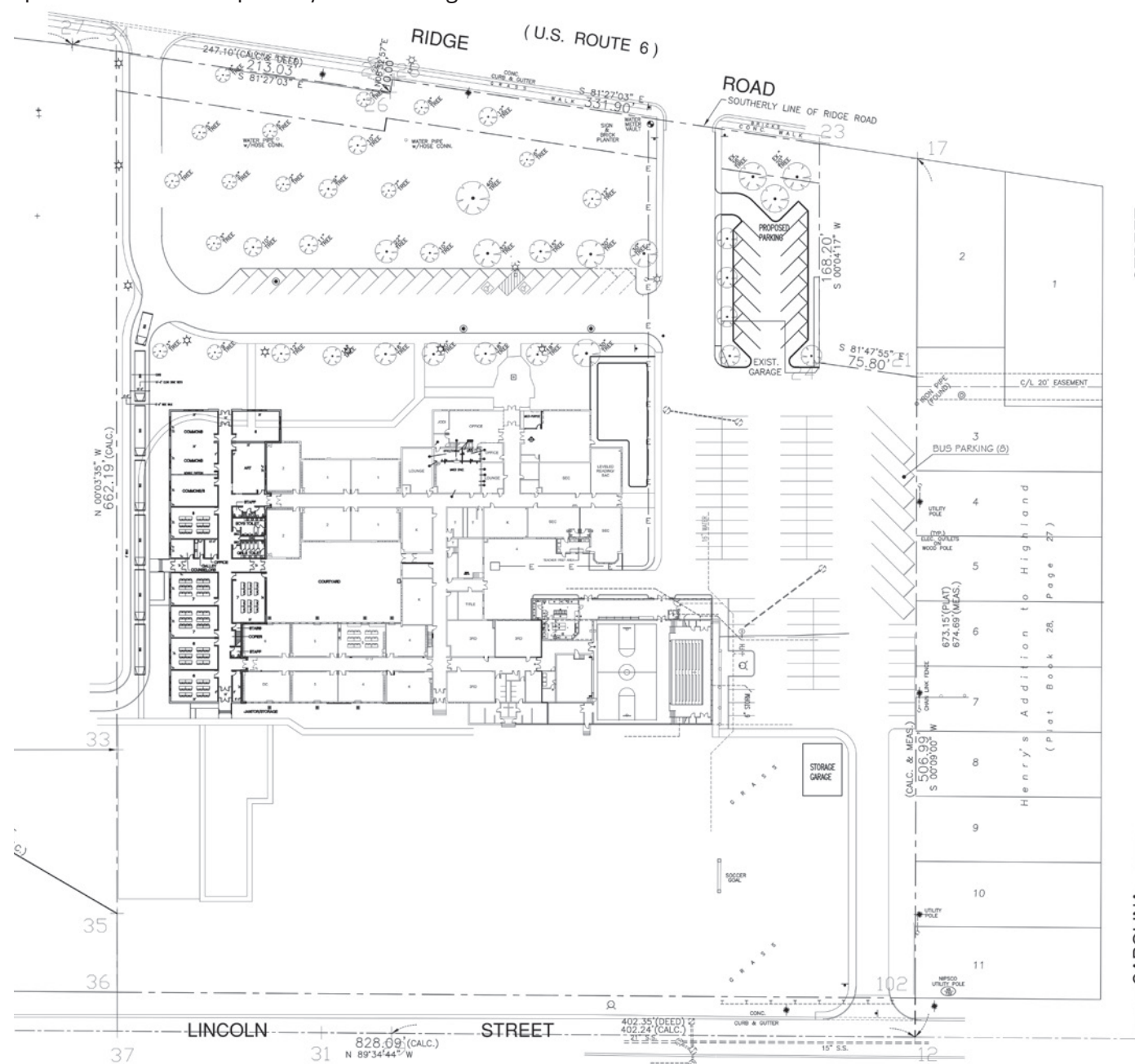

## etc... A Thrift Store Seeing God At Work

By Hallie Van Kley

We can see how the Lord is moving at etc... A Thrift Store more than ever! Whether it is seen from the servant's hearts in our volunteers and employees, our wonderful customers, or the way He is always prospering us through the bumps life may bring, it is obvious that God has etc in the palm of His hand. We are constantly told by our customers how much they love etc and what we support here, and I have to believe it is because they can see the light of the Lord in this business. While this winter season has brought some challenges, God has never failed to get us through each one. We are looking forward to what He is going to do with etc this spring and summer!



Hallie has been part of the etc... family since 2020. Currently she works as a shift leader part time. In addition to this, she hosts a blog at [www.lifewiththelamb.org](http://www.lifewiththelamb.org) through which she shares her personal faith with the Lord. Graduating high school in 2021, she is now pursuing becoming an author full time through courses at home. She is also starting a business selling her watercolor art on Instagram (Instagram: @jirehwatercolor). When asked about this chapter of her life, Hallie replied, "I aspire to glorify the Lord with the dreams He has placed in me, and I am so excited to see what He has for me through writing and painting, and I love working at the thrift store!"



# Cultivating Community PTO Highlights

By Miss Jodi Lineburg

We're always excited to celebrate and cultivate relationships at HCS! Over the past few months we've enjoyed a Spring Break Scavenger Hunt, and Family Fun Fair. While our journeys may differ, we're all in it for our kids and the work God is doing in their lives!



## SGO Scholarship Update

Highland Christian School's community did it again! You provided 56 families with an SGO Scholarship. SGO Scholarships provide a gateway into the Indiana Choice Scholarship Program. Each year, Highland Christian School provides eligible families with this scholarship to ensure that they can start their little ones in Christian School to begin with. Typically, we award between 12 to 14 family scholarships annually. Due to legislative changes in the summer of 2021, this need quadrupled in 2022! That means you gave a whopping \$28K! What a great expression of God's love, support and generosity! Thank you for partnering with parents to ensure that finances are not the factor that keeps children from getting a Christ-centered, covenant-model Christian education!

## Secured School Safety Grant Update

By Miss Jodi Lineburg

We are pleased to report that the new on-bus camera systems were installed this Spring! These cameras were purchased with funding through the Indiana Department of Homeland Security Secured School Safety Grant. Great thanks to Midwest Transportation for their installation services. This project is now moved to a use and maintenance phase.

The LORD has granted us safety as we transport children to and from school and we are especially grateful for the people who coordinate and plan for this: Mrs. Nancy Scheeringa, Transportation Chair, Mrs. Ann Lynch, Transportation Coordinator, and Mr. Wes Blocker, HCS Mechanic.



# HCS Foundation

By Ms. Jodi Lineburg, Development Director

## Change for the Future

We are pleased to announce a new initiative for the HCS Foundation called, "Change for the Future!" On permanent display at HCS is a large jug and plaque denoting that "Every penny counts! Every dollar makes a difference. "Contribute your coins and IMPACT KIDS FOR CHRIST with the HCS Foundation!"

Fund development and long-range investing are the observable activities of Highland Christian School's Foundation. However, the Foundation does so much more! This group of individuals serves to strengthen and protect covenant Christian education, keeping Christian education affordable for generations to come by enabling growth, encouraging generosity, and perpetuating the beliefs, values and priorities for which Highland Christian School was established.

If the Foundation is new to you, you can learn more online at [www.highlandchristian.org/foundation](http://www.highlandchristian.org/foundation)

In the meantime, bring your coins in and take a walk through Highland Christian School! You'll be delighted to see the difference your dollars are making in the lives of students today!

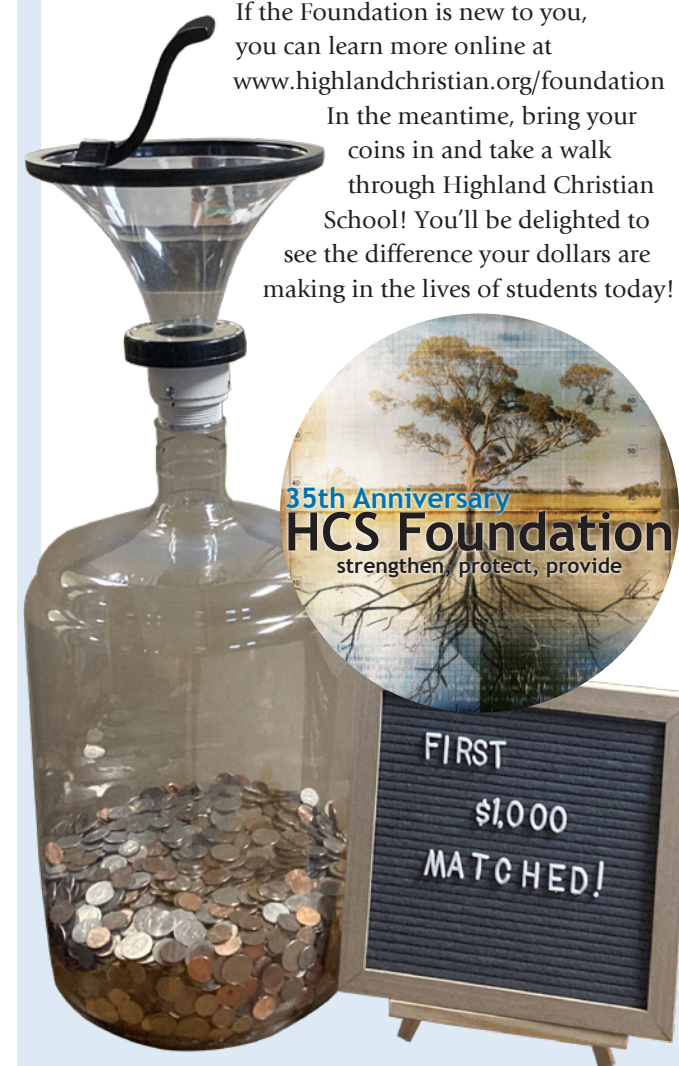

## Stewarding A Gift

By Miss Jodi Lineburg

Christ-centered education is truly a gift! As a community-supported Christian School we are blessed by the generosity of believers who help meet financial needs that fall outside of the annual budget. Most of these needs are planned, some are emergent; almost all are time-bound. Highland Christian School's Foundation takes things a step further.

Highland Christian School's Foundation takes giving a step further. Friends of the Foundation are community members who are invested in the future well-being of Highland Christian School. They give NOW to ensure that we are strong and thriving for FUTURE generations. They connect the dots of "now" and "not yet", that which is visible to that which is envisioned. We carry the testimony of what God has done with all that He is yet to do. This is the joy that comes with stewarding the gift of Christ-centered education.

Highland Christian School's Foundation is pleased to provide tax-advantaged giving opportunities that align your best with God's best so that kids are impacted by Christ and prepared to impact the world for Christ through their education at Highland Christian School. Learn more by visiting [www.highlandchristian.org/foundation-35-years](http://www.highlandchristian.org/foundation-35-years).

## School Improvement Plan & Accreditation Update

By Mr. Kyle Weener and Miss Jodi Lineburg

We are pleased to continue with Christian Schools International for our ongoing supervision and accreditation. Having completed the goals of our current school improvement plan in 2021, our School Improvement Team has been busy this year evaluating, documenting, and planning for our next 5-year plan. A site visit team will be on campus in the Fall of 2022 to review and affirm the goals we identify. We are blessed and grateful for the fantastic, hard working team of teachers, staff and community members who are involved in writing this plan. At present we have completed three of the four required tasks and we're thankful to God for the blessing of His leading as we plan for opportunities that lay before us.

# SUPPORT HCS

- Auction
- Church Offerings
- Estate Gifts
- etc...Thrift Store
- Family Legacy Funds
- Foundation Fund
- Fundraising Events
- Gifts of Stock
- Hope Fund
- Legacy Prayer Plaza
- PTO
- School Improvement Fund
- SGO Scholarship Fund
- Tribute Gifts
- Tuition Assistance Fund
- Wish List Fund



HIGHLAND CHRISTIAN SCHOOL

3040 Ridge Road, Highland, Indiana 46322

219-838-0356

www.highlandchristian.org

NONPROFIT  
ORGANIZATION  
U.S. POSTAGE  
**PAID**  
GRIFFITH, IN  
PERMIT NO.14

## HCSF GOLF OUTING 2022

By Mike Natelborg, HCSF Board Member

With the overwhelming support of last year's HCSF Golf Outing, we are excited to announce another golf outing this year. We had a great turnout last year at Briar Ridge Country Club with over 130 golfers and almost 40 sponsors. The HCS Foundation was blessed to raise over \$17,000 to help the future of Christian education.

We sincerely appreciate all the support from last year, and hope you decide to join again this year to support HCS. If you did not have the chance to attend in 2021, we hope you consider coming this year for a great time of fellowship, friendly competition, and support of Christian education. Please review the details of this year's event:

**Monday, August 29, 2022**

**Briar Ridge Country Club**

**11:00am - 6:00pm** Dinner will be served at 5pm

**Price Estimated \$150.00 per golfer**

Sponsorships offered for business marketing and additional golfers

**Includes Door Prize, Golf Scramble at Briar Ridge, Lunch & Dinner, and Raffle Items**

**More information to come, but please mark it on your calendars!**

*"Train up a child in the way he should go and when he is old, he will not depart from it."*

- Proverbs 22:6

# HCSF GOLF OUTING 2022

## Monday, August 29, 2022

### Briar Ridge Country Club

#### 11:00am - 6:00pm

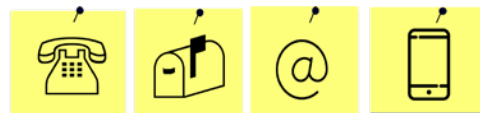

## Time to UPDATE?

Your experience and insights can impact kids for Christ at Highland Christian School. **WILL YOU BE PART OF THE PACK THAT COMES BACK?** Update your information with us today!

**SUBMIT YOUR UPDATE AT [WWW.HIGHLANDCHRISTIAN.ORG/ALUMNI](http://WWW.HIGHLANDCHRISTIAN.ORG/ALUMNI)**

Getting your children's mail? Let us know! We'd love to send it straight to them.

Give us a call at 219.838.0356 or send an email to [jlineburg@highlandchristian.org](mailto:jlineburg@highlandchristian.org).

Thanks in advance for your help!